



7

Maintenance for Torque Tools

7-1 Daily Check 108

7-2 Adjustment Method

- (1) Adjustment of torque tools 109
- (2) Adjustable type torque screwdriver 110
- (3) Pre-set torque screwdrivers 111
- (4) Adjustable torque wrenches
 - 1) Below adjustable 420N models, except for QL2/5/10/15N, QL25N5, CL2/5/10/15N, CL25N5 112
 - 2) Adjustment of QLE2, CLE2 113
 - 3) Settle main graduation scale position below adjustable 420N models, except for QL2/5/10/15N, QL25N5, CL2/5/10/15N, CL25N5 114
 - 4) Settle main graduation scale position above adjustable 550N models 115
- (5) Pre-set torque wrenches 116
- (6) Dial indicating torque wrenches 118

7-3 Parts Replacement

- (1) Replace ratchet part 119
- (2) How to attach locker for adjustable torque screw driver 120
- (3) Dial Indicating Torque Wrench 121

7-4 Parts list

- (1) QL 122
- (2) DB 124

7-5 Cross-section Drawings 126

Tohnichi Adjusting Tools

Maintenance of torque tools needs in-depth understanding about their structure and methods of torque adjustment and repair, and also Tohnichi adjusting tools are required.

For learning adjustment or repair methods, consult Tohnichi or nearest distributors.



Adjusting tool for LTD/RTD models:

Used for torque adjustment (zero point) of LTD / RTD models



Thrusting tool for SP models:

Used for torque adjustment or disassembly of preset type torque wrenches



Adjusting Tool for QSP3, SP2 models:

Used for torque adjustment of QSP3, QSP4, SP2, RSP2 and QSPCA.



Adjusting tool for DB models:

Used for torque adjustment of dial indicating type torque wrenches as well as T-s and DOT models

7

Maintenance for Torque Tools

-1 Daily Check

Torque tool daily check can help to find any damaged or missed parts on the early stage, and this prevents users from serious accidents.

Unlike the periodical calibrations, the evaluation standards of the daily check are determined based on the comparison between the result of this time and the last time.

Table 7-1.Daily Check List

Check list		How to check	Evaluation standard	Repairable/Unrepairable
Torque value	Torque value	Visually	Whether it can definitely confirmed.	Repairable
	Tendency	Operation test with tester	When the value vary a lot from previous time's, or over the regulated tolerance.	
Scale	Dirt/stain	Visually	Vague	Repairable
	Scratch	Visually	Vague	
	Aberration of scale line	Visually	Scale and standard line is not aligned	
Outside appearance	Crack	Visually	Yes・No	Unrepairable
	Peeling metal coating	Visually	Yes・No	
	Rust	Visually	Yes・No	
	Bend of tube	Visually	Yes・No	
	Deformation of tube	Visually	Yes・No	
	Serial number	Visually	Whether it can definitely confirmed.	
Ratchet	Abnormal ratchet rotation	Turn ratchet right & left or shake while holding	Unstable or unusual rotation sounds.	Repairable if parts replaced
	Ball plunger missing/wearing	Visually Insert and remove a socket/bit.	Ball plunger missing Socket/bit easily fallen out	
	Ratchet lever missing	Visually		
	Screw missing/loosening	Visually		
Parts	Unable to lock sub-scale	Tighten locker	Locker hits the spring pin	Repairable
	Head pin rattling	Visually		Repairable if parts replaced
	Sub-scale missing	Visually		
	Locker missing	Visually		
	Extension handle missing/loosening	Visually		

When you find something wrong other than shown on the above list, repair it or ask your nearest Tohnichi distributor for repairing immediately.

7

Maintenance for Torque Tools

-2 Adjustment method

(1) Adjustment methods for torque tools

For a graduated torque measuring tool, coordinate the scale torque value with the measured torque value by repeating the zero point correction and the gain adjustment several times. (Figure 7-1)

Zero point correction

For the zero point correction (Figure 7-1), the scale values are increased or reduced by the same quantity (C) against the measured torque values.

Gain adjustment

For the gain adjustment (Figure 7-1), the scale values are magnified or reduced almost proportionally to the measured torque values at a certain rate (α).

Central point

If the error at the central point of the full-scale span is too large, carry out the above zero-point correction and gain adjustment.

If the error is still too large even after the procedure, the torque tool must be disassembled and repaired.

Figure 7-1.
Adjustment figure

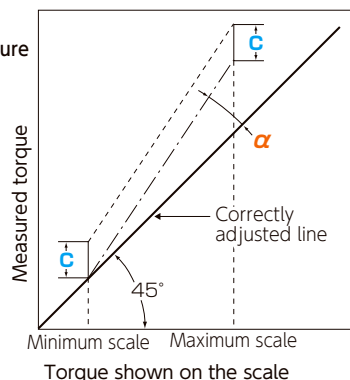

Adjusting procedures for adjustable type torque tools

- ① Set the torque tool to the minimum scale value.
- ② Correct the value to the minimum scale value with the torque tester zero point correction, parallel shift (C).
- ③ Set the value of the torque tool to the maximum scale value.
- ④ Adjust the value to the maximum scale value with a torque tester gain adjustment, multiplying shift (α).
- ⑤ Confirm the value adjustment by repeating procedures ①~④.

Adjusting procedures for indicating type torque tools

- ① Correct the value of the torque tool to the zero point, zero point correction, parallel shift (C).
 - ② Load the torque tool with the maximum torque value using the torque tester and read the scale value.
 - ③ Release the load and correct the value by adjustment gain adjustment, multiplying shift (α).
 - ④ Confirm the adjusted value by repeating procedures ①~③.
- * Torque wrenches that do not have adjusting devices are not adjustable.

Table 7-2. Torque tool zero-point correction and gain adjustment locations

Type	Model Name	Zero Point Correction	Gain Adjustment
Beam type torque wrench	SF, F, QF, CF	Needle bending	Scale plate replacement
Dial indicating torque wrench	DB, DBE,T	Dial rotation	Dial lever
Adjustable torque wrench	QL, PQL, QLE2, CL, CLE2	Sup. graduation replacement	Correcting screw
Dial indicating torque screwdriver	FTD	Needle or spring bracket rotation	Vertical movement of spring seat
	FTD-S, FTD2-S	Scale rotation	
Adjustable torque screwdriver	LTD, RTD, AMLD, BMLD, AMRD, BMRD	Zero adjusting screw or shim	Correcting screw
Power torque tool	U, ME, AP2, AUR	Scale ring	Torque adjusting screw

7

Maintenance for Torque Tools

-2 Adjustment Method

(2) Adjustable type torque screwdrivers

Table 7-3. Rate of torque change for adjustable type torque screwdrivers (LTD, RTD)

Model	Gain adjustment	Zero point adjustment		Adjusting tool	Fixing screw tightening torque value [cN·m]
	Rate of torque change (V) [cN·m/rev]	Rate of torque change (I) [cN·m/rev]	Remarks	Catalog No.	
RTD15CN/LTD	- 9	0.8	Zero adjusting screw 1 rev	51	60
RTD30CN/LTD	- 17.8	1.6		46	90
RTD60CN/LTD	- 42	4.2		47	190
RTD120CN/LTD	- 70	10		48	220
RTD260CN/LTD	- 154	10		49	
RTD500CN/LTD	- 322	33.3		50	
LTD1000CN	- 654	66.6		—	
LTD2000CN	- 1120	67.0 (t=0.1 [mm])	Shim adjustment t = 0.1, t = 0.2, t = 0.5	—	—

※ The rate of torque change is reference use only

Adjustment of adjustable type torque screwdrivers

- Loosen the set screw.
- Match the scale to the minimum scale value, set the tool on a tester, and measure the operating torque.
- Turn the zero adjusting screw to match the scale value with the actual measured value.
CW : Torque value increase
CCW: Torque value decrease
Note: The zero adjusting screw should be turned while the gain correcting screw is in the tightened condition.
- Match the scale to the maximum scale value, set the tool on the tester, and measure the operating torque.
- Turn the gain correcting screw to match the scale value with the actual measured value.
CW : Torque value decrease
CCW: Torque value increase
Note: The gain correcting screw should be turned while the zero adjusting screw is in the tightened condition.
- Repeat procedures ③ to ⑤ until min./max. value are within the accuracy range.
- Tighten the set screw, and reconfirm the operating torque at each measurement point.

$$\text{Number of turns of the zero adjusting screw} = \frac{T - T_0}{I \text{ (Amount of torque change)}}$$

$$\begin{array}{l} \text{Set torque } T = 60 \text{ [cN}\cdot\text{m]} \\ \text{Measured torque } T_0 = 55 \text{ [cN}\cdot\text{m]} \end{array} \quad \frac{60 - 55}{10} = 0.5$$

Since $360^\circ \times 0.5 = 180^\circ$, you are required to turn the zero adjusting screw 0.5 turn (180°) clockwise.

$$\text{Number of counterclockwise turns of the gain correcting screw} = \frac{T - T_0}{V \text{ (Amount of torque change)}}$$

$$\begin{array}{l} \text{Set torque } T = 260 \text{ [cN}\cdot\text{m]} \\ \text{Measured torque } T_0 = 280 \text{ [cN}\cdot\text{m]} \end{array} \quad \frac{260 - 280}{-154} = 0.13$$

Since $360^\circ \times 0.13 = 47^\circ$, you are required to turn the gain correcting screw 0.13 turn (47°) counterclockwise.

Figure 7-2. Detailed illustration of parts during adjustment

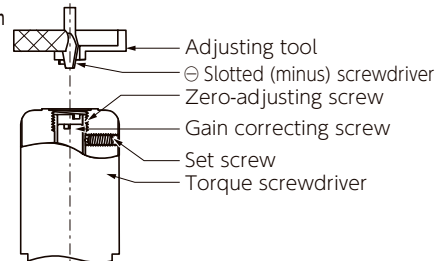

(3) Pre-set type torque screwdrivers

- ① Insert the adjusting tool into the hole of adjusting screw (bottom of the driver). Turn right: torque increases
- ② Set a driver on the loading device of the torque driver tester (TDT3-G).
- ③ Turn CW the loading device and measure the torque value.
- ④ Repeat the procedure ①~③, and adjust accuracy.

Figure7-3.Names of parts for pre-set type torque driver

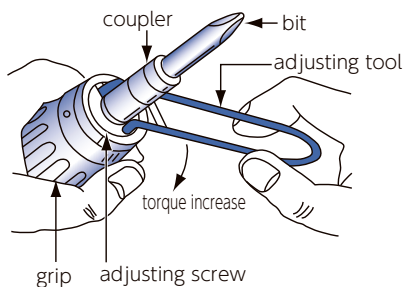

Table 7-4. Rate of torque change for pre-set type torque driver (NTD, RNTD)

model	Rate of torque change per a revolution [cN·m / rev]	Adjusting tool Catalog No.
RNTD15CN NTD15CN	7.7	42
RNTD30CN NTD30CN	9.8	
RNTD60CN NTD60CN	21.1	
RNTD120CN NTD120CN	32	43
RNTD260CN NTD260CN	62.7	
RNTD500CN NTD500CN	160.7	44
NTD1000CN	272.7	

※ The rate of torque change is reference use only

Torque screw driver tester with torque screw driver fixed



7

Maintenance for Torque Tools

-2 Adjustment method

(4) Adjustable torque wrenches

1) Adjustment of adjustable torque wrench below 420N

(Except for the following models: QL2N. 5N. 10N. 15N. QL25N5. CL2N. 5N. 10N. 15N. CL25N5)

- ① Loosen the locker, and turn the supplemental graduation to set it to the minimum scale value.
- ② Set the torque wrench on a tester, apply loading and confirm the operating torque. Turn the supplemental graduation to match the actual measured value as the minimum scale value.
- ③ Remove the spring pin using nippers.
- ④ Rotate the locker counterclockwise to remove it.
- ⑤ Replace the supplemental graduation so that the "0" of the scale is shown in the scale window.



Supplemental graduation

- ⑥ Attach the locker.
- ⑦ Rotate the supplemental graduation clockwise to match the maximum scale value. Set the torque wrench on the tester, apply loading and confirm the operating torque.
 - In the case where the actual measured value is lower than the scale value, turn the correcting screw counterclockwise (CCW).
 - In the case where the actual measured value is higher than the scale value, turn the correcting screw clockwise (CW).

Note: The correcting screw should be turned while the torque wrench is in the operating condition.

- ⑧ Repeat procedures ① to ⑦ to repeat the adjustment until both the minimum value and maximum value are within the accuracy range.
- ⑨ When both the minimum value and maximum value are within the accuracy range, tap in the spring pin. The position for tapping in the spring pin should be where the supplemental graduation is free to rotate when the locker is loosened, but allowing the supplemental graduation to be fixed when the locker is tightened.

Figure7-4. Locker and spring pin correct position

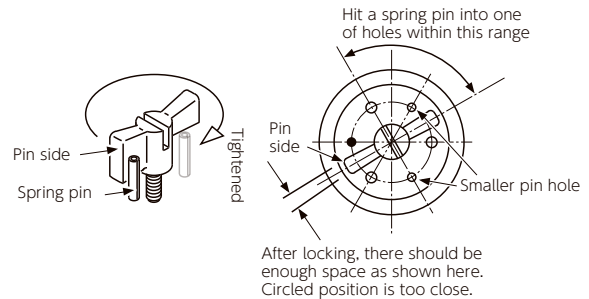
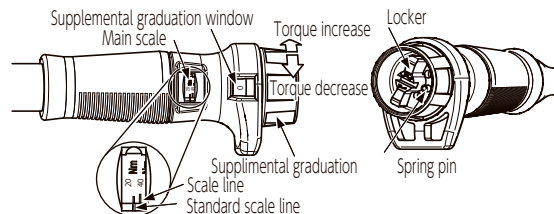

Figure 7-5. Torque setting details



2) Adjustment of QLE2, CLE2

- ① Set the torque wrench on a tester, apply loading and confirm the operating torque. Turn the supplemental graduation to match the actual measured value as the minimum scale value.
- ② Loosen the fixing screw of the subsidiary scale ring. Keeping the subsidiary ring fixed, match the measured value with the minimum scale value by turning the adjusting screw with adjusting box, and then tighten the fixing screw of the subsidiary scale ring (tighten at 138N.m).

Figure 7-6. Supplemental graduation adjustment

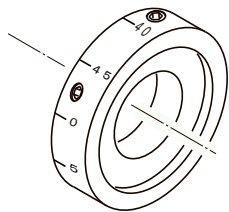

- ③ Make sure the “0” of the scale can be shown from the scale window correctly.
- ④ Set the torque wrench to its maximum torque, and set on the tester.
 - If the measured value is lower than the scale value, turn the adjusting screw CCW.
 - If the measured value is higher than the scale value, turn the adjusting screw CW.

Note: Adjusting screw must be turned when the wrench operated.
- ⑤ Repeat procedure ① ~ ④ until the accuracy reaches within the accuracy range.

Table 7-5. Rate of torque change for adjusting screw

Model	Rate of torque change by adjusting screw per a revolution (Max. scale, CW)	Flat to flat distance of the adjusting wrench
QL1.5N4	0.4	1.27
QL3N4	0.9	
QL6N4	1.7	
QL12N4	3.5	
QL2N	0.4	
QL5N	1.4	
QL10N	2.9	1.5
QL15N	4.3	
QL25N5	6.4	
QL50N	14	2
QL100N4	23	
QL140N	33	
QL200N4	45	2.5
QL280N	63	
QL420N	83	
QLE550N	96	
QLE550N2		
QLE750N	130	3
QLE750N2		
QLE1000N	190	
QLE1000N2	180	
QLE1400N	340	4
QLE1400N2	230	
QLE2100N	380	
QLE2100N2	300	
QLE2800N2	440	

※ Torque Δ is for reference use only.

7

Maintenance for Torque Tools

-2 Adjustment method

3) Settle main graduation scale position below adjustable 420N models, except for QL2/5/10/15N, QL25N5, CL2/5/10/15N, CL25N5

- ① Confirm the value of both Min. and Max. are within accuracy range, and check the deviation of scale.
- ② Remove the spring pin using nippers.
- ③ Remove Locker.
- ④ Remove graduation. Sup and seat.
- ⑤ Measure the depth from end surface to thrust ring.
- ⑥ Loosen thrust ring screw by using hex key.
- ⑦ Remove thrust ring.
- ⑧ Remove adjusting screw and scale piece assembly.
- ⑨ Remove stop plate.
- ⑩ Remove main spring and seat.
- ⑪ Apply Ever Torque (P.491) inside tube.
- ⑫ Insert a shim (for adjusting scale) between seat and main spring, and insert it inside tube.
- ⑬ set stop plate inside tube.
- ⑭ Insert scale piece.
- ⑮ Reassemble the thrust ring and put it in until it reaches to the depth measured in procedure ⑤. Decide the scale position so that the value on the sub scale is going to be the center of the scale window.
- ⑯ Tighten the thrust ring screw at the required torque value (see P.117 table7-7).
- ⑰ Combine sub scale seat and sub scale.
- ⑱ Put a washer on locker, and lightly tighten locker (pin will be fixed after adjustment).
- ⑳ Adjust torque value (see P.112).
- ㉑ Hit a pin into locker (see P.112).

Figure 7-7. Scale adjustment for adjusting type torque wrench (sectional)

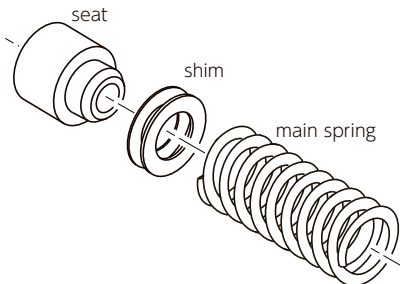
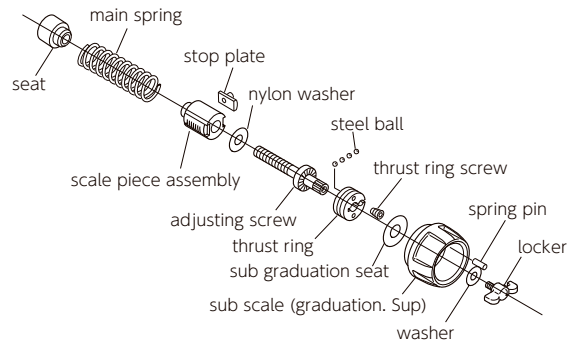

Figure 7-8. Scale adjustment for adjusting type torque wrench (whole)



4) Settle main graduation scale position above adjustable 550N models

- ① Confirm the value of both Min. and Max. are within accuracy range, and check the deviation of scale.
- ② Adjust the scale line.
if the line deviates to the head side from standard line: adjust scale to the Max. value.
if the line deviates to the sub scale side from standard line: adjust scale to the Min. value.
- ③ Slide the scale by a chisel and small hammer to adjust the scale line and standard line position.
- ④ Confirm the positions of scale line and standard scale line are align. Punch the three positions of the scale piece to fix the memory.

Figure 7-9. QL scale adjustment

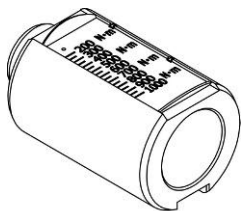

- ⑤ Check if scale is not moved pushing it with chisel.

Figure 7-10. Scale line deviation

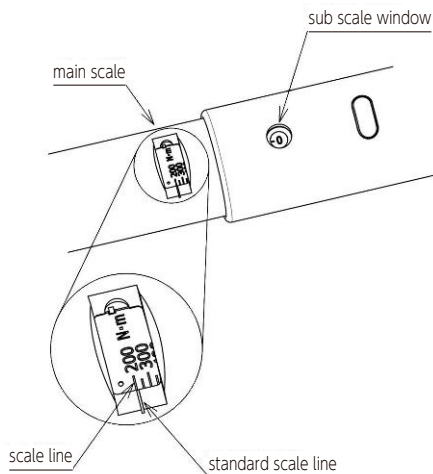

Figure of installation of a torque wrench on a torque wrench tester.

7

Maintenance for Torque Tools

-2 Adjustment method

(5) Pre-set torque wrenches

Adjusting method for pre-set type wrench varies depending on models. Please check the model name of your torque wrench.

1) QSP (1.5N4 ~ 280N3), QSPCA, SP2 (2N2 ~ 310N2), RSP2 (8N2 ~ 310N2)

- ① Insert the adjusting tool (Table 7-6) into the hexagonal hole with pin at the end of the wrench main unit
- ② Set the torque wrench on a tester, apply loading, and read the torque when the toggle operates. Adjust the setting torque by turning the adjusting screw, and repeat several times until the value comes close to the torque setting that you want to achieve.

CW: Torque value increase

CCW: Torque value decrease

- ③ Then inspect the set torque value with the tester five times or more to confirm that the torque value has become stable.



QSP4



Torque adjustment for QSP (1.5N4 ~ 280N3), QSPCA, SP2 (2N2 ~ 310N2), RSP2 (8N2 ~ 310N2)



SP2



QSPCA

Table7-6. Adjusting tool for QSP3, SP2, RSP2, QSPCA

Torque wrench model name	Adjusting tool	
	Catalog No.	Tip shape [mm] Hex x Bore x Depth
QSP1.5N4 ~ QSP25N3/CSP	931	2.5 × 1.5 × 6
QSP50N3 ~ 280N3/CSP	930	4 × 2.5 × 8
SP2N2 ~ 19N2,RSP8N2 ~ RSP19N2	931	2.5 × 1.5 × 6
SP38N2 ~ SP310N2/RSP2	930	4 × 2.5 × 8
QSPCA6N, 12N	931	2.5 × 1.5 × 6
QSPCA30N, 70N	930	4 × 2.5 × 8

2) SP (420N, 560N), QSP (420N)

- ① Set the wrench on a torque wrench tester, apply loading, and read the torque when the toggle operates. Adjust the setting torque by turning the thrusting with the thrusting tool, and repeat several times until the value comes close to the torque setting you want to achieve.
- ② Then inspect the set torque value with the tester three times or more to confirm that the torque value has become stable, and tighten the thrusting screw with the specified torque. (Table7-7)
- ③ Tighten the cap by turning it clockwise using the thrusting tool.
CW: Torque value increase
CCW: Torque value decrease
- ④ Inspect the set torque value with the tester five times or more to confirm that the torque value has become stable. And tighten thrusting screw with set torque (Table7-7).
- ⑤ Tighten cap by thrusting tool.

Figure 7-11 QSP torque adjustment

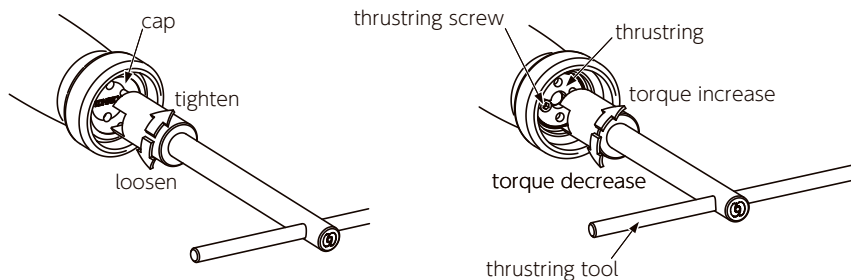

Table 7-7. Torque adjustment for SP and QSP models

Torque wrench model name		Thrusting tool		Thrusting screw		Thrusting	Cap
SP	QSP	No.	Catalog No.	Width across flats B[mm]	Tightening torque T[N·m]	a1/d1 [mm]	a2/d2 [mm]
—	QSP1.5N~QSP6N/CSP	A-1	310	1.5	0.5	6.8/2	6.8/2.2
SP2N ~ SP19N	QSP12N/CSP	A-2	311			9/2.5	9/3.2
SP38N, 67N	—	A-3	312	2	2.0	12/3	12/3.2
SP120N ~ 220N	—	A-4	313	3	3.0	16/3	16/3.2
SP310N	—	A-5	314			18/3	18/3.2
SP420N, 560N	QSP420N/CSP	A-6	315			20/3	20/3.2

7

Maintenance for Torque Tools

-2 Adjustment method

(6) Dial indicating torque wrenches

- ① Remove the back cover using the thrusing tool (P.107 table 7-7)
- ② Set the torque wrench in the tester so that a counterclockwise torque will be applied, and apply preloading. (Tester should carry this out in RUN mode.)
- ③ Release the preloading, and carry out zero adjustment both of the tester and torque wrench.
- ④ Again, set the torque wrench in the tester so that a counterclockwise torque will be applied, and apply loading up to the torque wrench maximum specified value. Read the value on the tester. (Tester should carry this out in RUN mode.)
- ⑤ In the case where there is a discrepancy between the tester value and the torque wrench indicated value:
 - When the tester value is lower than the torque wrench indicated value, the sector should be widened.
 - When the tester value is higher than the torque wrench indicated value, the sector should be compressed.
- ⑥ Repeat procedures (4) and (5) until the values are within the accuracy range.
- ⑦ Set the torque wrench in the tester so that a clockwise torque will be applied, and apply preloading. (Tester should carry this out in RUN mode.)
- ⑧ Release the preloading, and carry out zero adjustment both of the tester and torque wrench.
- ⑨ Again, set the torque wrench in the tester so that a clockwise torque will be applied, and apply loading up to the torque wrench maximum specified value. Read the value on the tester. (Tester should carry this out in RUN mode.)
- ⑩ In the case where there is a discrepancy between the tester value and the torque wrench indicated value:
 - When the tester value is lower than the torque wrench indicated value, the sector should be widened.
 - When the tester value is higher than the torque wrench indicated value, the sector should be compressed.
- ⑪ Repeat procedures (9) and (10) until the values are within the accuracy range.
- ⑫ Install the back cover to the main unit rear window.

Figure 7-12

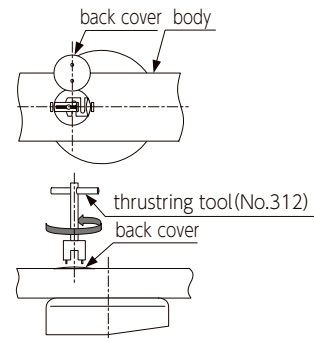
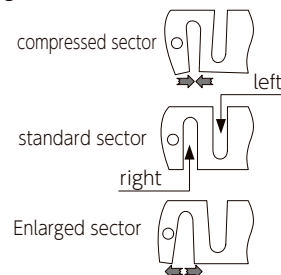

Figure 7-13



(1) Replace ratchet part

1) Disassembling the ratchet

- ① Remove the flat head screw (Phillips or hexagonal) using a screwdriver or hexagon key.
- ② Remove the head cover from the head and ratchet.
- ③ Remove the ratchet assembly.
- ④ Take out the ratchet springs. (Be careful that the ratchet springs do not spring out.)
- ⑤ Remove the head saws.

2) Reassembling the ratchet

- ① Insert the head saw axis part back into the hole of the head of the head.
- ② Install the ratchet springs between the ratchet and the head saws so that the springs' small diameters are touching the head saws. (Be careful that the ratchet springs do not spring out.)
- ③ Insert the ratchet assembly while pressing down on the head saw.
- ④ Install the head cover, centering the hole over the ratchet.
- ⑤ Place some screw adhesive on a small plate and apply a small quantity into the hole of the head cover. (Be careful not to get the adhesive on the inside parts.)
- ⑥ Tighten the flat head screw (Phillips or hexagonal), using a torque screwdriver or torque wrench.

Figure 7-14. Ratchet spring position

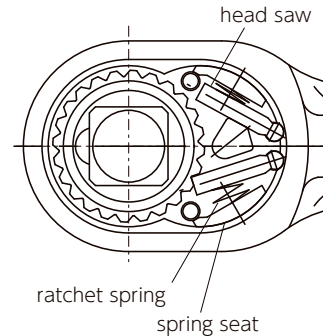

Table 7-8. Tightening torque for head screw

Model	Tightening torque (N·m)
QL2N ~ QL25N5/QSP	0.78
QL50N ~ QL140N/QSP	1.42
QL200N ~ QL420N/QSP	3.30
QLE550N2 ~ QLE1000N2	7
QLE1400N2 ~ QLE2800N2	11.6

(2) How to fix locker of adjustable torque screwdriver

- ① Set the main scale and sub scale.
- ② Apply grease into the holes of roller, and put roller on each hole.
*Be careful of rollers for RTD260CN, sharp side should be upward.
- ③ Insert locker (white dot of the locker should be the next to LOCK mark), and turn it counter clockwise.
Make sure the ▼ marks and white dot can match up.
- ④ From coupler side, insert locker pieces until hear snap sound.
*Watch the direction of locker piece, the flat side should be with the RTD case side.
- ⑤ Confirm the locker works correctly.

Figure 7-15 Assembling RTD locker

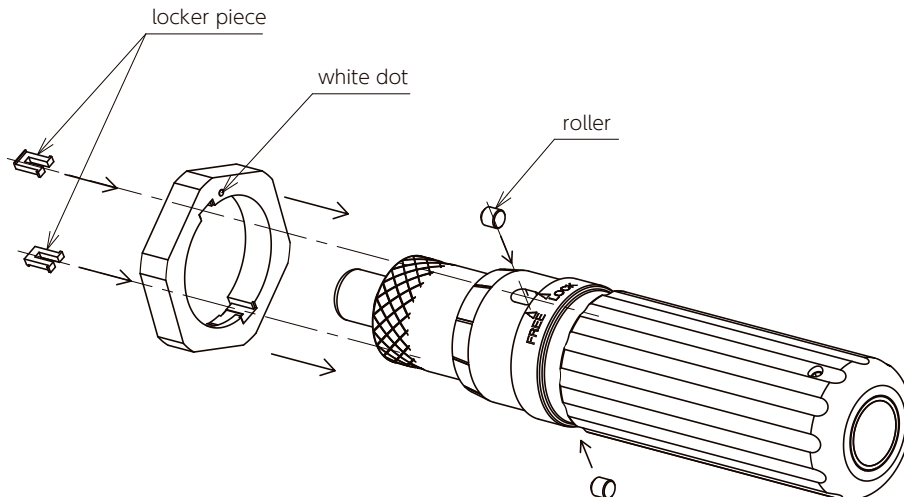
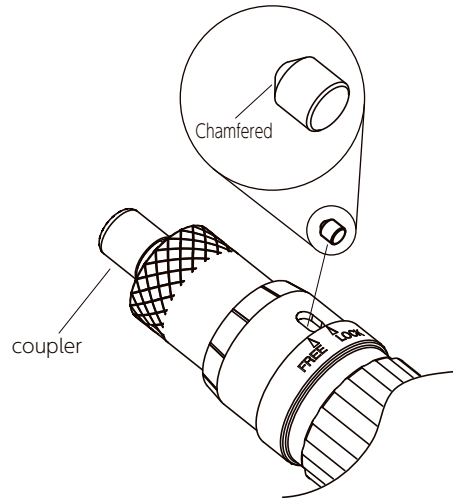

Figure 7-16. Direction to set the roller

Sharp side is set to the coupler side



(3) Dial indicating torque wrench

A : Disassembling the dial gauge

Figure 7-17

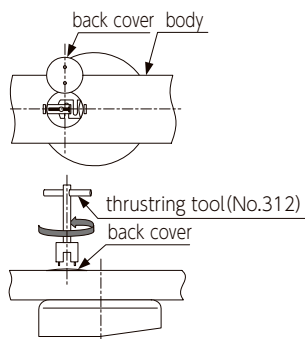

- ① Rotate and remove the back cover with the thrusting tool (P.99 Table 7-5)
- ② Remove the protector cover. (DB1.5N4 to DB280N)
- ③ Set the notched part of the glass plate so that it is parallel with the tube.
- ④ Hold the body in a vice, insert the special tool (P.491) between the protector and the dial gauge assembly and pry off the glass plate.
- ⑤ Pull off the needle using the special tool.
- ⑥ Take off the scale plate.
- ⑦ Take off the spring plate.
- ⑧ Loosen the two M3 screws with a Phillips screwdriver.
- ⑨ Lift up the dial gauge assembly and take off the sector pin of the dial gauge assembly from the groove of the dial bar while confirming using the rear window of the main unit.
- ⑩ Remove the bracket from the protector.

B : Reassembling the dial gauge

Figure 7-18

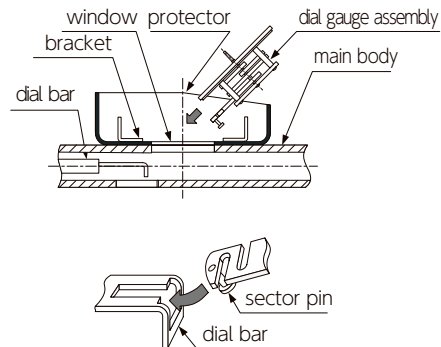

- ① Place the bracket back in the center of the main unit protector.
- ② Insert the dial gauge assembly into the main unit window from above the bracket. Insert the sector pin into the groove of the dial bar. (confirm using the round window on the rear side.)
- ③ Apply screw adhesive to the screws of the protector.
- ④ Match the positions of the dial gauge assembly and the protector and tighten using the two M3 screws. (tightening torque 0.6 [N·m]) At this time, check the smooth rotation of the bracket.
- ⑤ Attach the spring plate.
- ⑥ Match the center hole of the scale plate with the dial gauge assembly axis, and assemble while aligning the bracket projections with the groove on the outside circumference of the scale plate.
- ⑦ Positioning the square drive of the main unit to the left and keeping it facing up, install the needle.
- ⑧ Insert the plate glass, matching it with the center of the bracket.

No.	Part Name	pcs/unit	Part NO.					
			QL25N	QL50N	QL100N4	QL140N	QL200N4	QL280N
1	Head	1	—	—	—	—	—	—
2	Head saw	2	02T26243	03T26243	01T48017	05T50449	02T48017	07T50449
3	Head cover	1	02T03360	03T03360	01T48013	05T50448	02T48013	07T50448
4	Cam	1	02T03361	03T03361	01T48020	04T03361		05T50694
5	Ratchet lever	1	02T04762	03T04762	03T04762	04T04762		05T04762
6	Ratchet spring	2	06T03405	05T03405	01T03405	11T03405	06T50450	12T03405
7	Ratchet assembly	1	00T16061B	00T16061C	00T48012A	00T16061W	00T48012B	00T50507B
10	Flat head screw	2	02T10312	03T50410	15T50410	05T50410	07T50410	07T50410
11	Tube	1	—	—	—	—	—	—
12	Thruster	1	06T12843	05T12843	08T06731		03T12843	02T37240
13	Toggle	1	06T50099	05T50099	08T50099		03T50099	
14	Roller	1	00T35308B	00T35308C	00T35308E		00T35308F	
15	Toggle pin	2	02T37432	03T37432	04T37432		05T37432	
16	Thrust ring	1	05T10339	01T10339	03T10339		03T05034	
17	Seat	1	06T05035	05T05035	04T50122		03T05035	
18	Sub graduation	1	02T50100	00T50102B	00T50104B		00T50106B	
19	Locker	1	04T50121	03T50121	03T50121		03T50121	
20	Adjusting screw	1	05T05031	01T05030	01T12405		01T50659	01T37556
21	Main spring	1	03T03924	04T03924	01T48019	09T03924	02T48019	05T37346
22	Stop plate	1	09T48019	05T04995	04T04995		03T04995	
23	Head pin	1	06T04995	05T05077	04T05077		03T05077	
24	Nylon tube	1	06T05077	02T03420	02T03420		03T03420	
25	Socket head screw	1	01003012607	01004015607	01004015607		01005020607	
26	Thrust ring screw	1	04T05188	02T05188		01T05188		
27	Steel ball	2	0703/321			07001/81		
28	Spring pin	1	050020074	050030084				
29	Sub scale seat	1	06T09483	05T09483	04T09483		03T09483	
30	Scale piece	1	01T09904	01T09905	01T09906	01T12404	01T50548	01T37555
31	Scale plate	1	01T50365	01T50366	01T50126	01T50368	01T50663	01T50370
32	Steel ball	4	0703/321			07000031		07001/81
33	Nylon washer	1	02T50320	03T50320	04T50320		05T50320	
34	Washer	1	01T50539	02T50539			03T50539	
35	Scale cover	1	01T50538	02T50538	03T50538		04T50538	
36	Sub scale cover	1	01T50267	02T50267	03T50267		04T50267	
37	Handle	1	01T46004	02T46004	03T46004		04T46004	05T46004
38	Spring seat	2	—	—	01T48014	01T45879	01T48015	01T45984
39	Graduation stopper	1	—	—	—	06T50493	08T50493	—
40	Scale pin	1	01T50575	051.2004				

7

Maintenance for Torque Tools

-4 Parts List

(2) DB

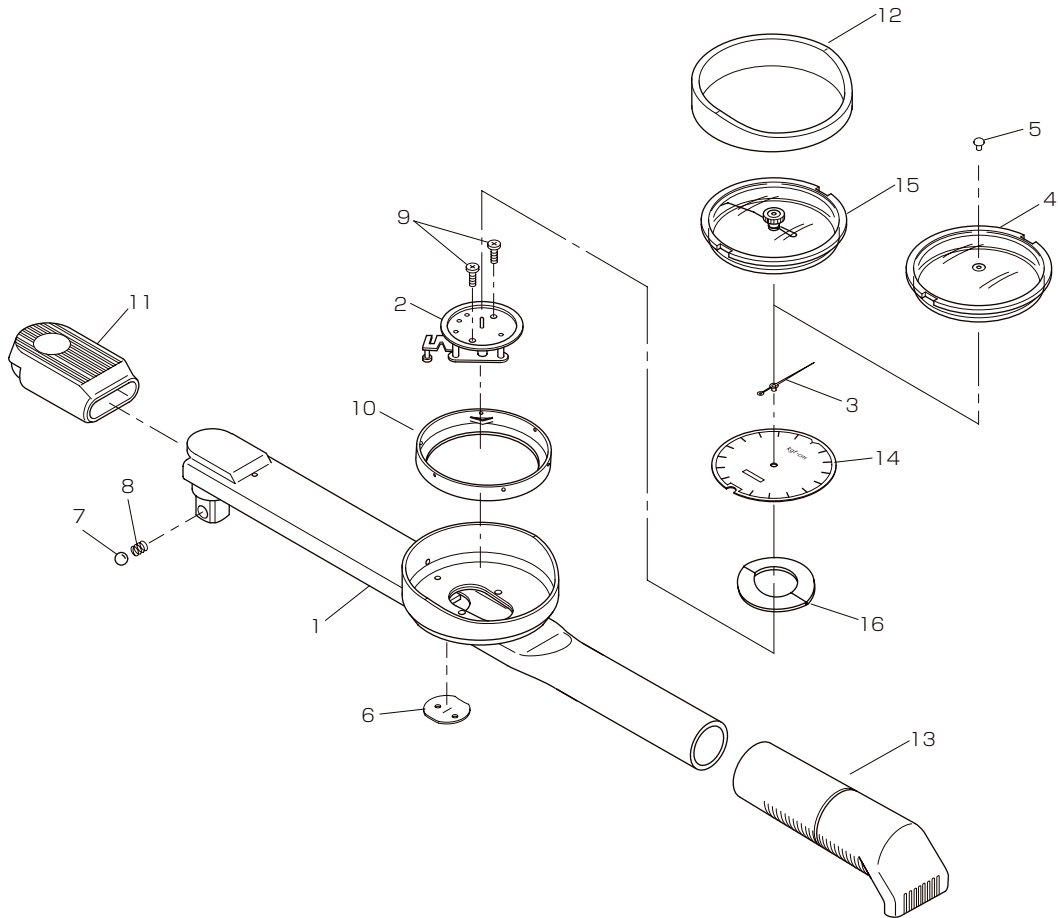

No.	PART NAME	QTY	PART No.					※ Note
			DB25N	DB50N	DB100N	DB200N	DB280N	
1	TUBE ASSEMBLY	1	—	—	—	—	—	
2	DIAL GAUGE ASSEMBLY	1	00T38056A				00T07741A	
3	NEEDLE	1	00T12088A					
4	PLATE, GLASS	1	01T28398					
5	RIVET	1	06002004014					Used for "non memory-pointer" model only.
6	COVER, BACK	1	01T08491					
7	BALL, STEEL	1	07000051		07000061		07000071	
8	SPRING, BALL	1	02T06494		03T06494		04T06494	
9	SCREW, FLAT HEAD	2	01003006202					
10	BRACKET	1	01T12087					
11	COVER, HEAD	1	01T28421	01T50383	01T50384	01T28423	01T28424	
12	COVER, PROTECTOR	1	01T50174					
13	GRIP	1	01T28410	01T28409	01T28406	01T28407	01T28408	
14	PLATE, SCALE	1	01T50193	02T50193	03T50193	04T50193	04T28663	
16	SPRING, PLATE	1	03T08172					
			-S					
15	S-S. IND. ASSEMBLY	1	00T16065F					

7

-5 Cross-Section-Drawings

AP2

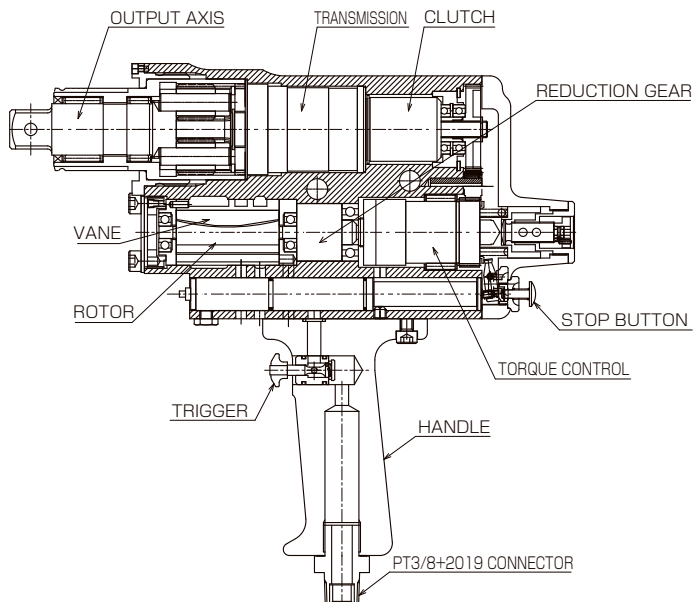

AC3

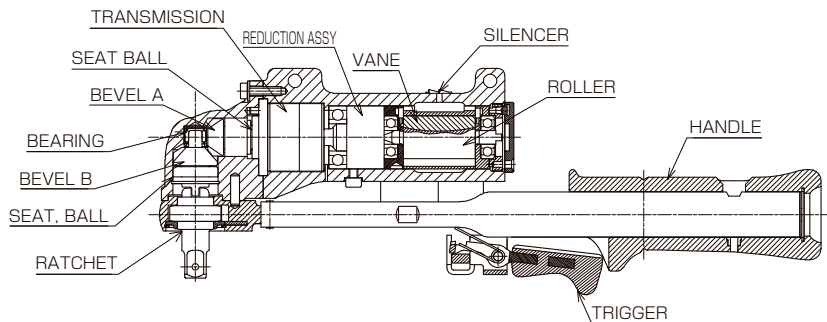
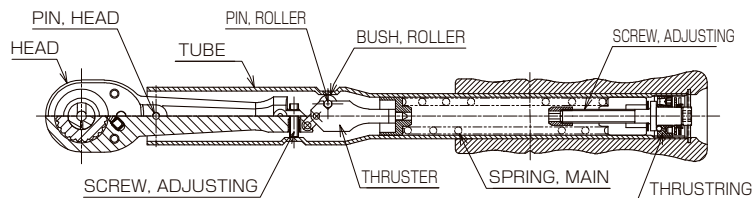

RTD (LTD)

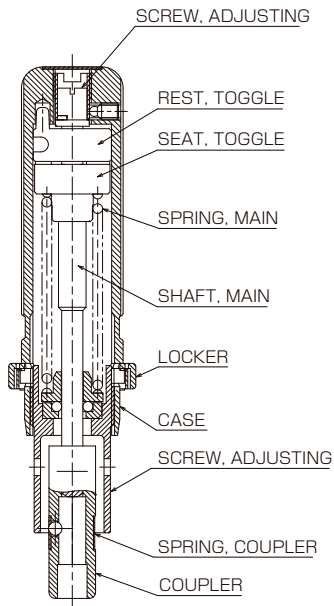

RNTD (NTD)

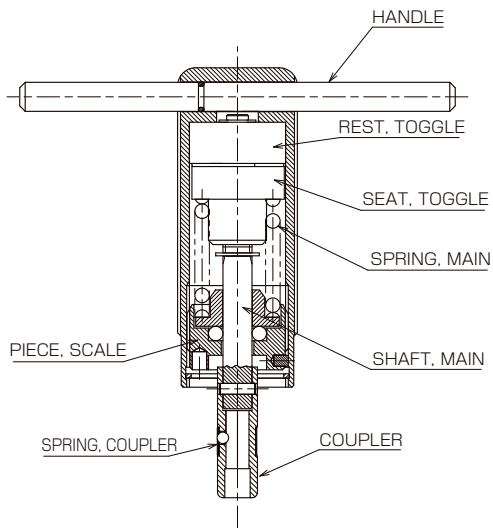

FTD2-S

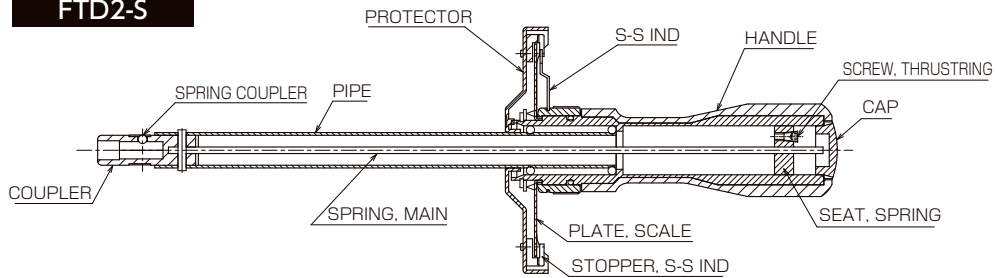

7

Maintenance for Torque Tools

-5 Cross-section Drawings

QL4

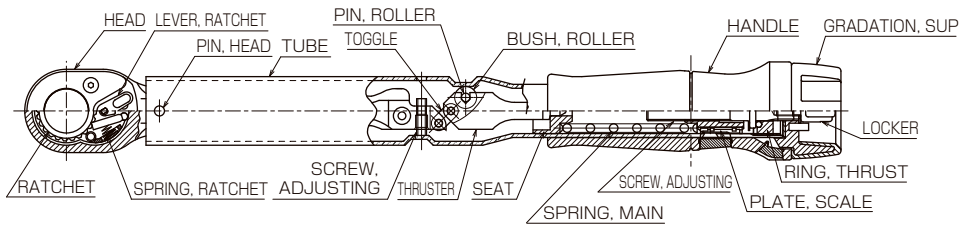

QL5

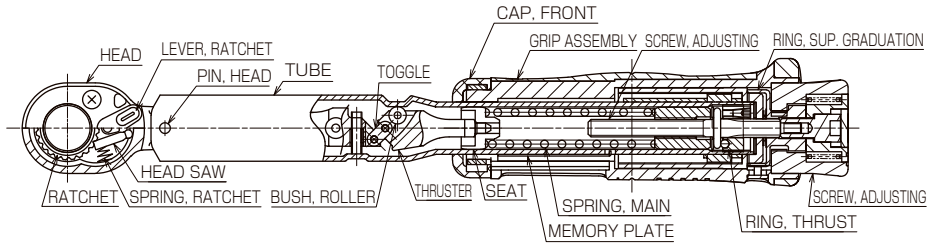

SP2

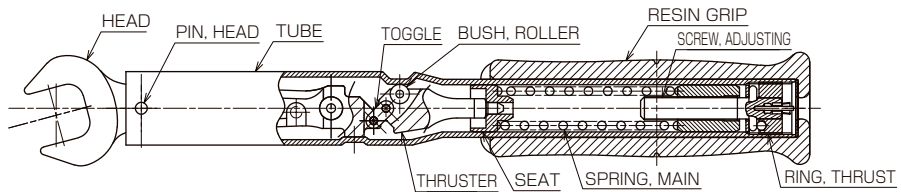

MPQL

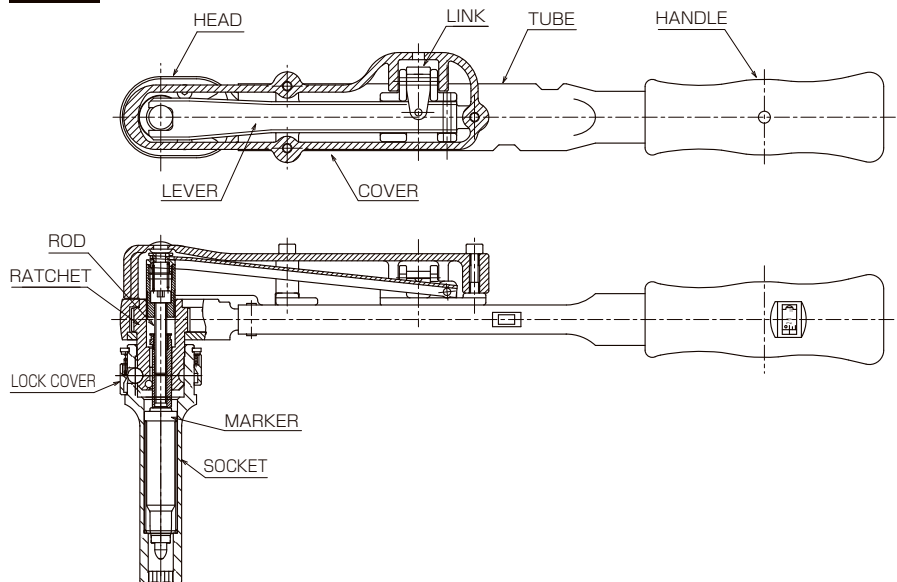

DB

